

Dimensional drawing of concrete anchors to be mounted on the ground

### ASSEMBLY LIST

PART	NAME	DIMENSION	QUANTITY
1	Table plate		1pc
2	Table leg		4pcs
3	WPC seat		4pcs
4	Backrest		4pcs
5	Black socket head cap screw	M10*20mm	48pcs
6	Concrete anchor	M10*120mm	4pcs
7	Maintenance door		1pc
8	Mounting base		



### STEP ONE

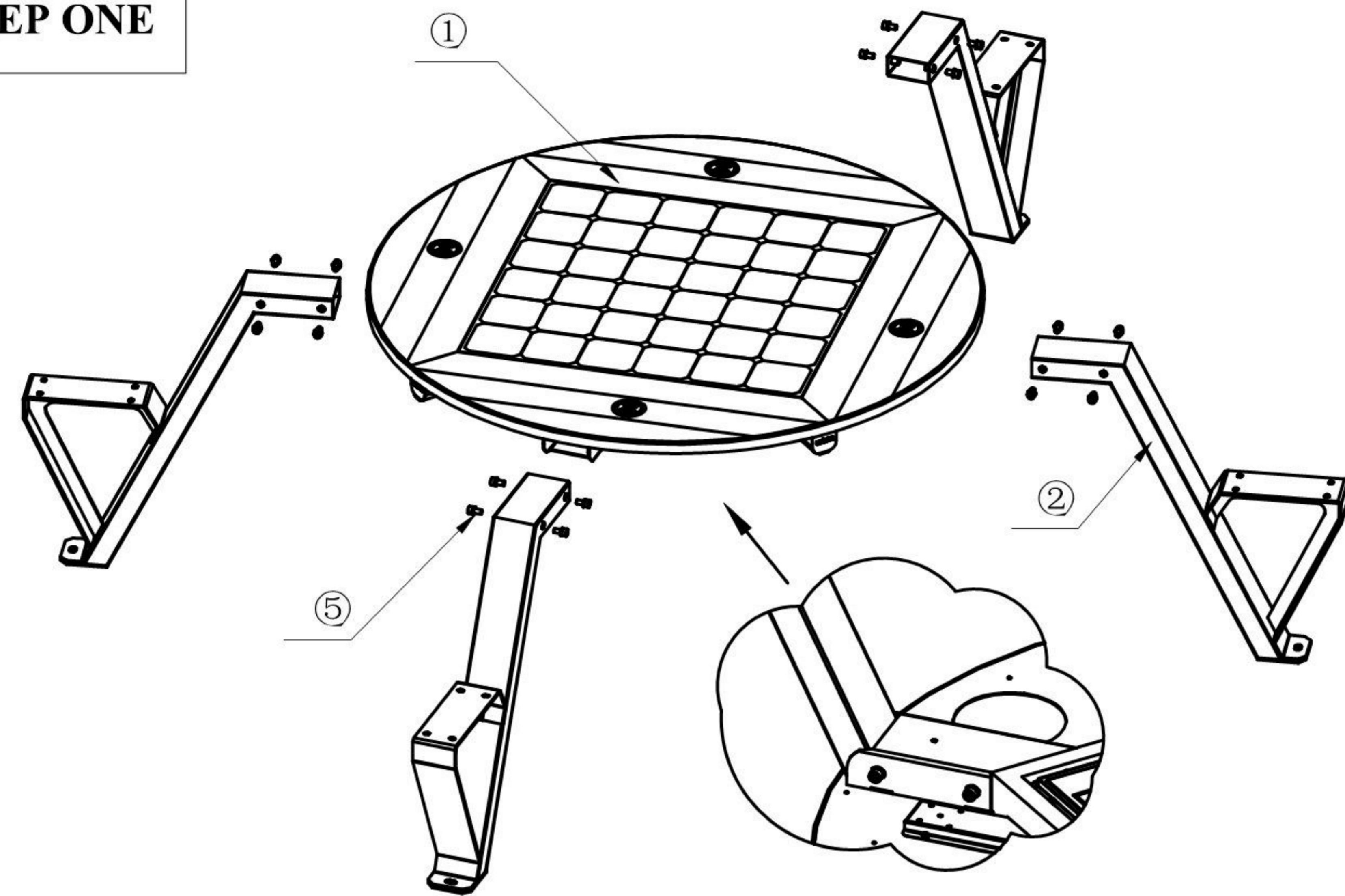

1. Align the four table legs (Item 2) to bolt holes in table plate (Item 1).  
Secure the 16 screws (Item 5) using 8mm hex wrench.

### STEP TWO

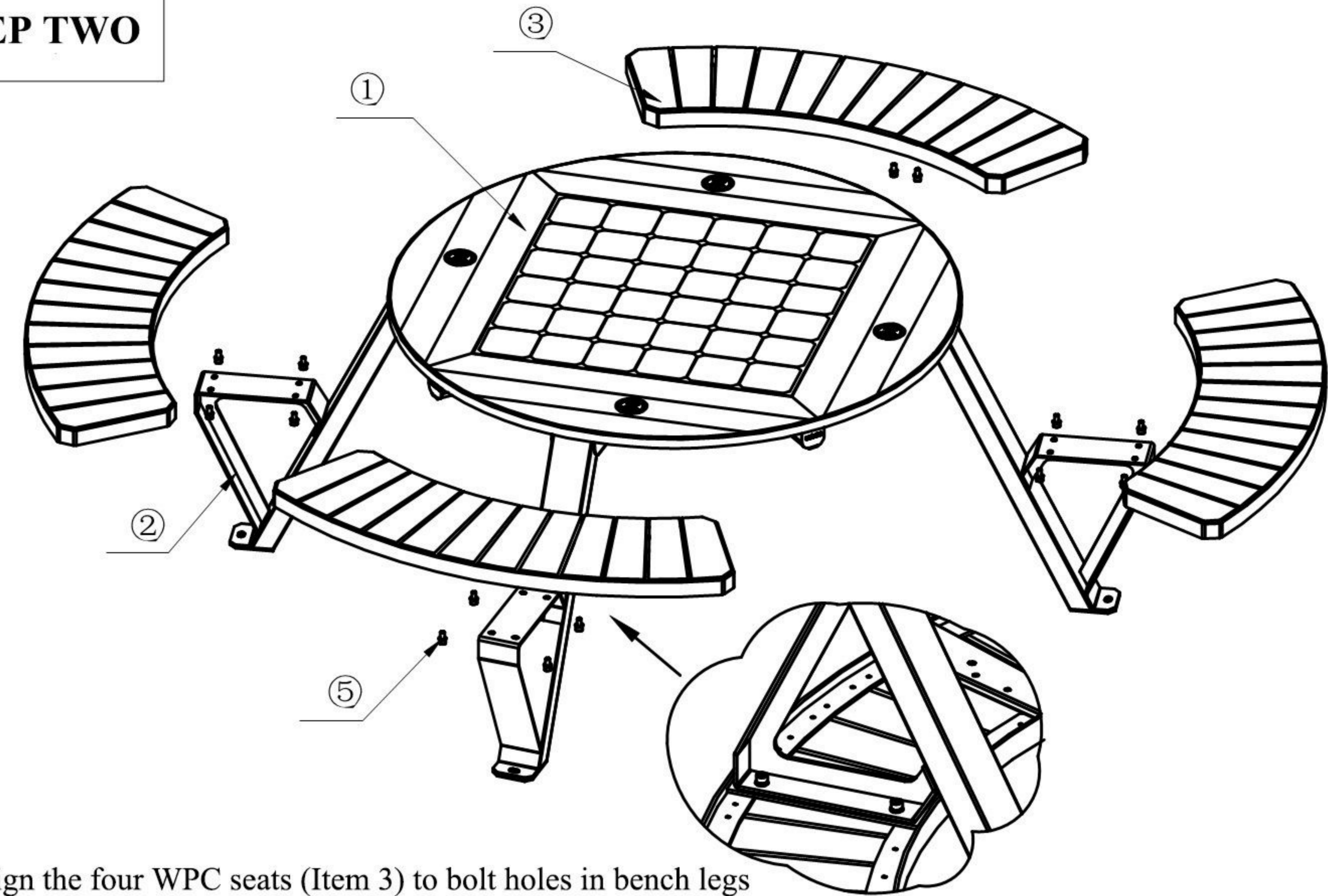

2. Align the four WPC seats (Item 3) to bolt holes in bench legs (Item 2). Secure the 16 screws (Item 3) using 8mm hex wrench.

### STEP THREE

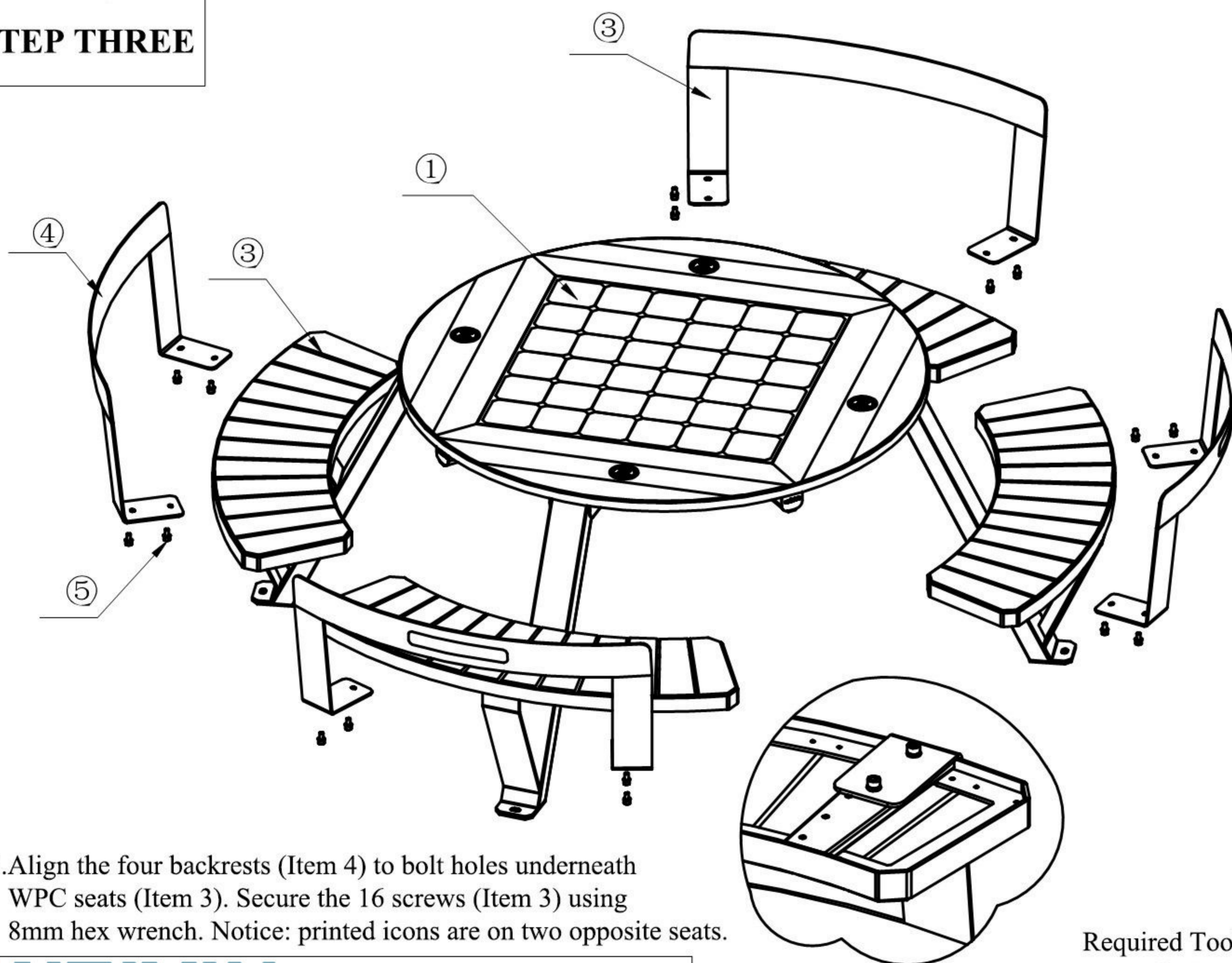

3. Align the four backrests (Item 4) to bolt holes underneath WPC seats (Item 3). Secure the 16 screws (Item 5) using 8mm hex wrench. Notice: printed icons are on two opposite seats.

**WEIYIN**  
**ADLIS**

**WYC1821 INSTALLATION INSTRUCTION**

Required Tools:  
Hex(Allen) wrench: 8mm  
Box end wrench: 16mm  
Phillips screw driver

Included Fasteners:  
M8\*20 Black socket head cap screws = 48pcs  
M12\*120 Concrete anchors = 4pcs

### STEP FOUR

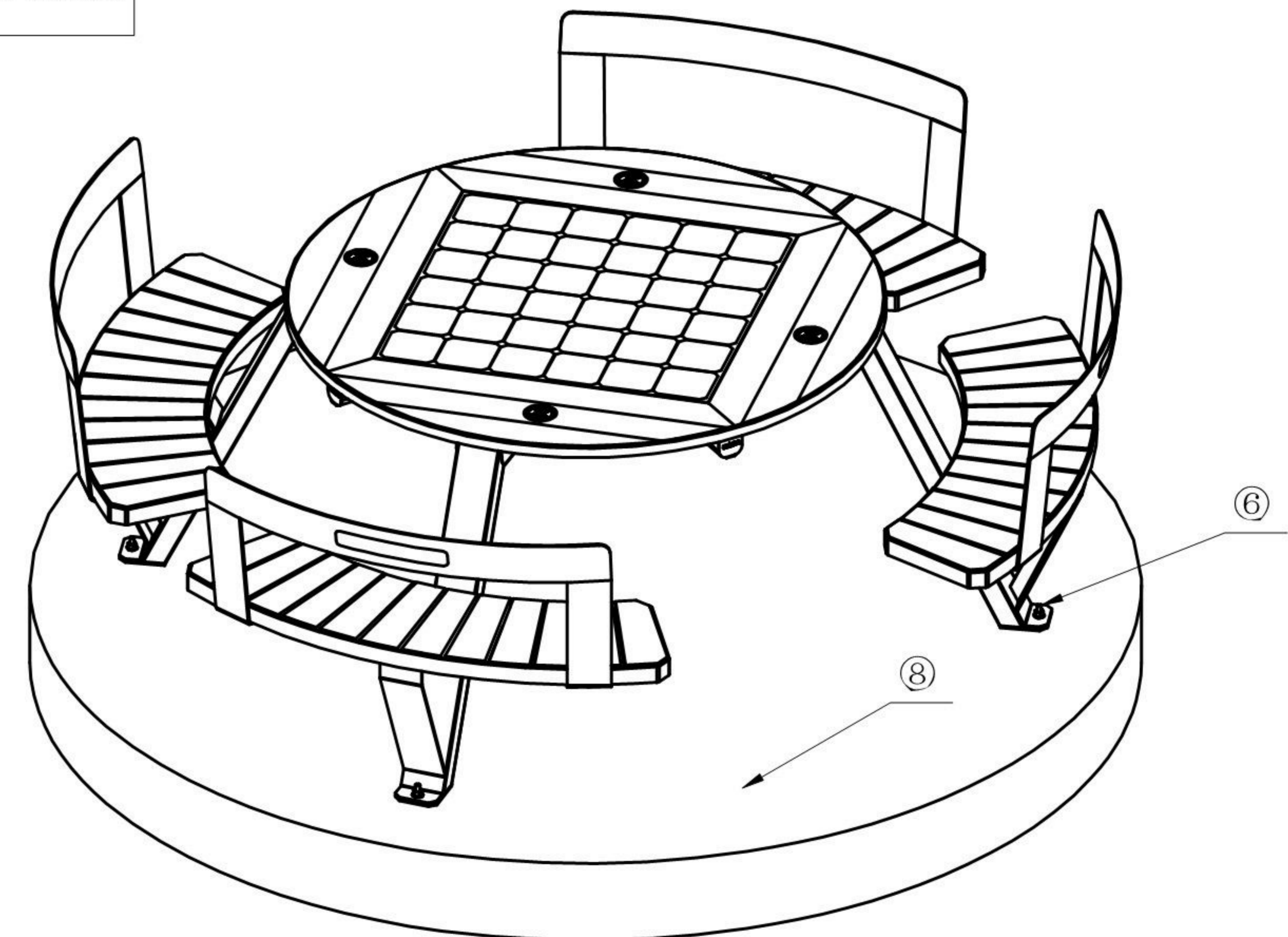

4. Select a flat surface for mounting the table. Drill holes in mounting base (Item 8) in configuration shown as step 4 to accept concrete anchors (Item 6). Secure expanding concrete anchors fully to holes and secure table legs (Item 2) to ground using 16mm box end wrench.  
5. Open maintenance door (Item 7). Turn on the power switch of battery and make sure all electronic components are working properly.  
6. Close the maintenance door (Item 7). Ensure all screws are fixed tightly to complete installation.